

The Winning Force

**DURMA**

# AD-S SERIES PRESS BRAKES



- Perfect Precision
- Deep And Fast Bending
- Efficient
- Winning
- Elegant Design



**DURMA** The Winning Force







---

As a total supplier for sheet metal manufacturing with almost 60 years of experience, Durma understands and recognizes the challenges, requirements and expectations of the industry. We strive to satisfy the ever higher demands of our customers by continuously improving our products and processes while researching and implementing the latest technologies.

In our three production plants with a total of 150.000 m<sup>2</sup>, we dedicate 1,000 employees to delivering high quality manufacturing solutions at the best performance-to-price ratio in the market.

From the innovations developed at our Research & Development Center to the technical support given by our worldwide distributors, we all have one common mission: to be your preferred partner.

Present Durmazlar machines with **DURMA** name to the world.



1  
High technology,  
modern production  
lines



2  
Top Quality  
Components



3  
High quality  
machines designed  
in R&D Centre

# The Winning Force

## Feel The Force and Performance

Our Machines are shaped with our superior experience and state of art technology, special designed as well as excellent combined component its the fastest , most reliable and prices press Brakes on its category.

With its rigid body structure, robust back gauge and high standard components it ensures long lasting and precision applications.

Therefore with *DURMA* press brakes you can always achieve perfect result.





---

# Fast, Precise and Perfect Bending

Precise bending result at fast speed

Minimum tool change and adjustment time

Maximum speed and safety



# AD-S Series Press Brake



# Perfect and Fast Bending

Perfect components for precision

With Easy to use control unit, stabile body type, perfect design, low operation cost, different tool usage options, maximum safety standards, *DURMA* press brake is the best in the world in its segment.



High  
Capacity

Robust  
Body

Perfect  
Precision

Winning

Ergonomic

## Why *DURMA* Press Brakes

- Better and faster bending
- Stronger and rigid body structure
- High sensitivity and repeatability
- Latest technology
- Low service cost
- Reliability

# Fast, Efficient, Modern

AD-S Series press brakes, designed with high technology to increase efficiency on precise part bending.

Quality approved components.

Stress relieved for long life and precise bending.



## General Specifications

- High sensitivity, Stress relieved steel construction body, long life Mono Block Frame
- Automatic calibration and first start up
- DURMA designed and copyrighted guiding system
- Ball Screw and linear guide integrated perfect back gauge system
- Durable, long life and sensitive bending capable special hardened top tools
- Suitable for segmented tools special and fast tool holding system
- Sensitive solutions on Long and deep bending
- High accuracy linear scales
- CE safety standards
- Best quality world wide accepted hydraulic and electric components



# Strong Back Gauge Systems

Precision

Reliable

Strong

- Fast and high accuracy
- Safe movement
- Resistance to crash
- Maintenance free
- Adjustment availability at every point

## Why *DURMA* Back Gauge ?

Most important feature to achieve perfect bending is the stability and the design of the back gauge, which allows an impeccable and correct product to be produced.

The high speed **ballscrew** back gauge system movement is also supported with **linear guides**, which helps the back gauge achieve long life, greater sensitivity and strengthens against any collisions.

Special designed finger blocks with steps to achieve maximum stability can also be supplied for every kind of bending solution.

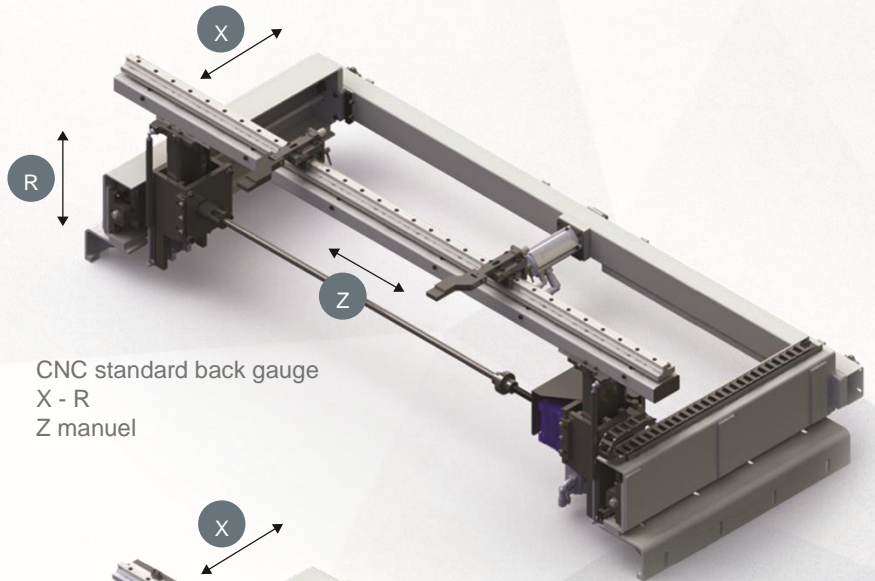

CNC standard back gauge  
X - R  
Z manuel

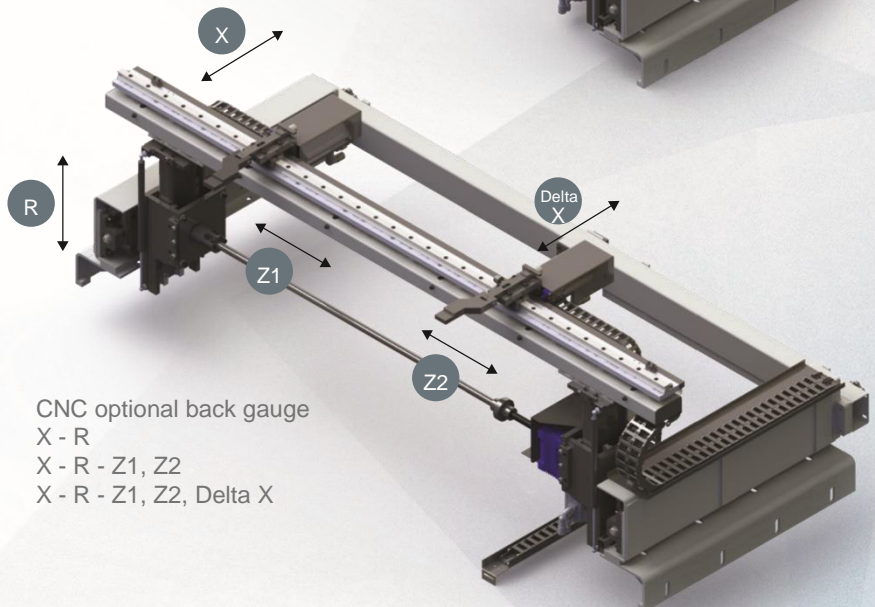

CNC optional back gauge  
X - R  
X - R - Z1, Z2  
X - R - Z1, Z2, Delta X

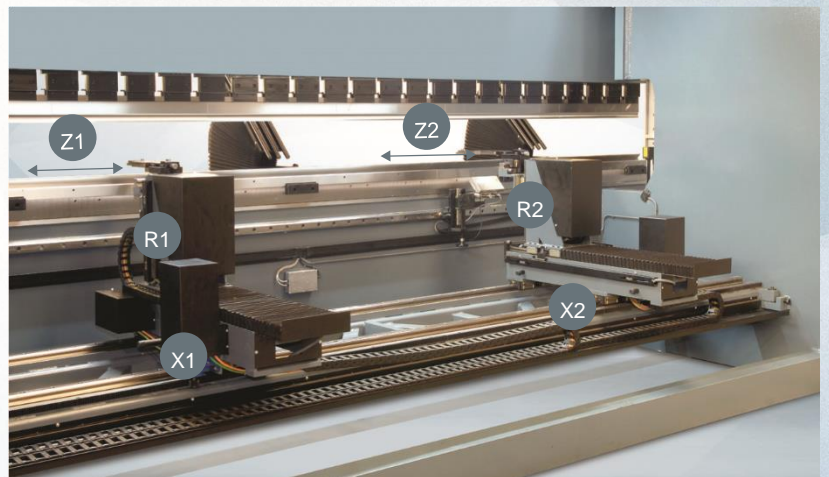

CNC optional back gauge  
X1 - X2, R1 - R2, Z1 - Z2

# Tool Holders and Tools

Bending performance increased using with high quality European clamping system and easy to use. Narrow table designed for European style tool holder and Z bending.

*DURMA* is your solution partner with various tool options.



European Clamping System

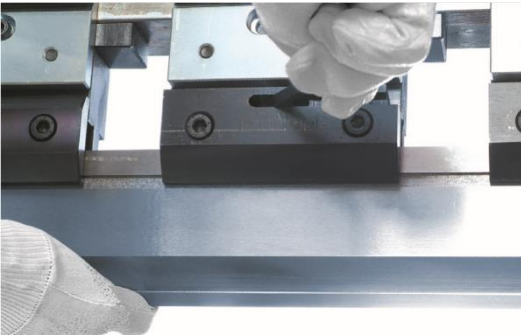

Quick Release Clamping



Wila Top Tool Clamping



*DURMA* Top Tool

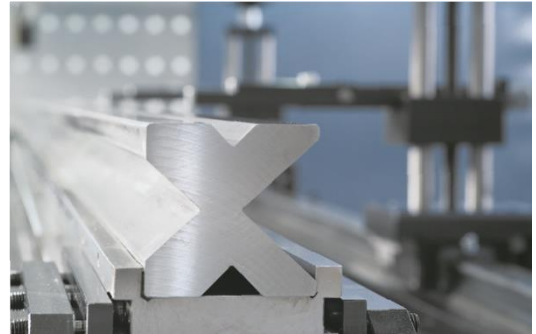

European Type Bottom Tool (4V Die)

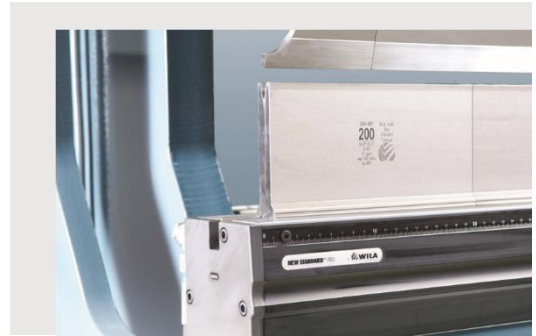

Wila Bottom Tool Clamping



*DURMA* Bottom Tool Multi V

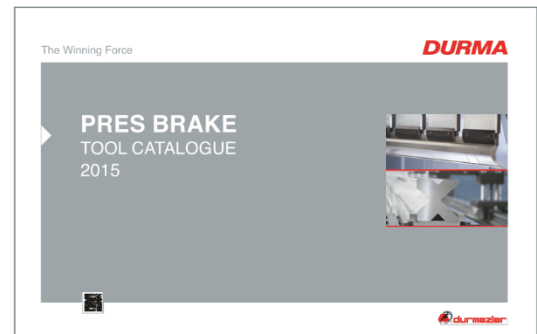



# Safe and Accurate Bends with Top Quality Equipments

## Crowning System

Manual or CNC-controlled motorized crowning system simplifies bending by adjusting each point of the bending parts to acquire straight bends. The need for shimming is eliminated.

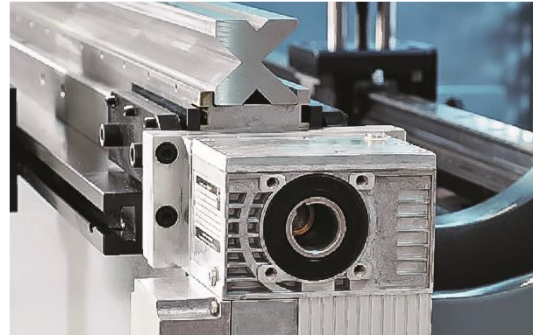

CNC Crowning System

## Linear Guide Front Sheet Supports

Rugged support arms with tilting stops are mounted on a linear guide rail system. This allows “finger-tip” lateral adjustment as required by the bend length of the part. They are also equipped with side gauges for the fast, easy, and accurate feeding of parts small or large.



Linear Guide Front Sheet Supports

## CE Safety Systems

Our machines are designed in accordance with Ce-Norms to ensure your safety with hydraulic, electric, appropriate height covers and laser light curtains. CE safety in tandem machines are also provided with light barriers

Ce Laser Safety System

## Stable Top Beam Movement

By using long and planar guiding surfaces, all the disadvantages of point guiding are eliminated 100%. free bending space: guiding system that eliminates bending between frame has been moved to the outside of the frame.

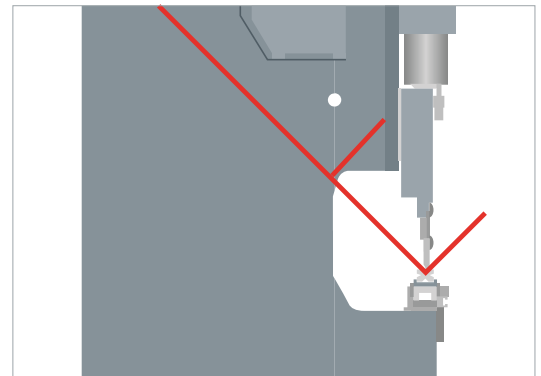

90 Degree Endless Bend



# Now Bending is More Easier

ModEva 15T



- 15" color Touch Screen
- On-screen finger profile drawing
- Automatic bend listing
- Very simple and convenient data transfer
- Higher productivity thanks to easy and rapid
- Multi-simulation capability
- Simulation criteria for better sheet management
- Windows XPe for multitasking and file management
- EC safety-cycle management
- Ethernet for Easy communication

## Bundled Offline Software

PC-ModEva software allows you to prepare your programs, calculate offers and check feasibility of the parts on your desktop computer. No time is wasted on the machine.

DA-66T



- 2D graphical touch screen programming mode
- 3D visualisation in simulation and production
- 17" high resolution colour TFT
- Full Windows application suite
- Delem Modusys compatibility
- USB, peripheral interfacing
- User specific application support within the controllers multitasking environment
- Sensor bending & correction interface

Modeva Premium

DA-69T

ANGLE MEASUREMENT



AP3 - AP4 SHEET FOLLOWER

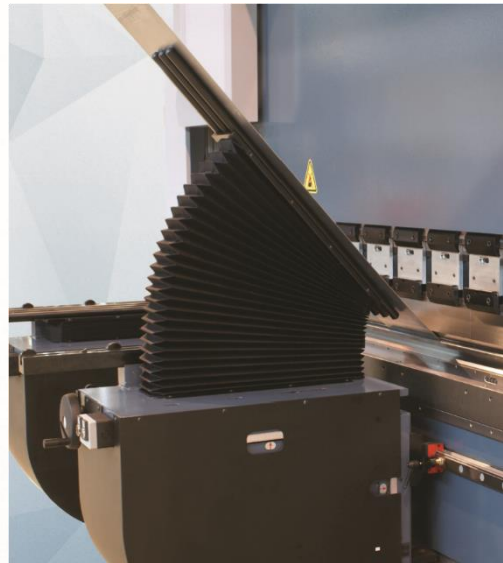

ROBOTIC SOLUTIONS





---

# Standard & Optional Equipment

## Standard Equipment

Y1, Y2, X, R - 4- axis  
Control Unit - CNC ModEva15T or 66T  
CE Manuel F. AKAS II M FPSC-B-C + safety covers with switch  
CE F.AKAS BVLV light barrier and safety covers ( for tandem press brakes)  
Servo motor back gauge & linear guided & ballscrew system (X-R)  
CNC crowning  
European style tool clamping system  
Sliding front arms (With T-Slot and stopper)  
World standards special design hydraulic block and valves  
World standard electric equipment

## Optional Equipment

Control unit - ModEva Premium or 69T  
FIESSLER AKAS-LC II AKAS-3 M Motorized + FPSC (safety PLC)  
CE BLVT safety – only for tandem machines  
Z1, Z2 axis  
X1, X2 axis  
R1, R2 axis  
R1 R2 axis on back gauge fingers  
Delta X axis,+250mm stroke  
X axis = 1000 mm – light barrier back protection  
AP3-AP4 sheet following system  
Motorized height adjustable laser angle measurement system  
Quick release clamping system  
Hydraulic and pneumatic tool clamping systems  
Bottom and top tools  
Bottom tool separation system  
Parking area  
Central lubrication system  
Oil cooler  
Additional back gauge finger and sliding front support arms  
Special packing for overseas shipments



---

# Fast on Service and Spare Parts

*DURMA* provides the best level of service and spare parts with qualified personnel and spare parts in stock. Our experienced and professional service personnel are always ready at your service. Our professional training and application enriched courses will give you an advantage to use our machinery.



Consultancy



Spare Parts

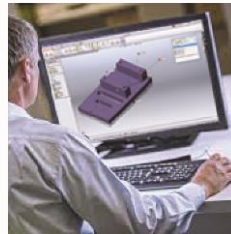

R&D Center



After Sales Service

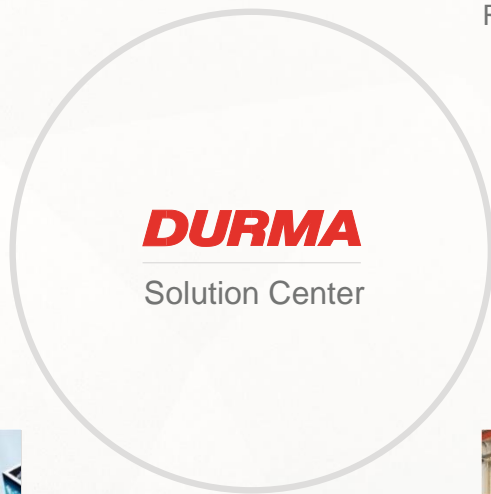

Service Agreements



Software



Training



Flexible Solution

# AD-S Series Technical Details

AD-S Series	Bending Force	Bending Length	Distance Between Columns	Stroke	Daylight	Throat Depth	Table Height	Table Width	Working Speed	
									Y Rapid Speed	Y Working Speed
									Ton	mm
	A	B	C	D	E	F	G			
AD-S 1260	60	1250	1050	265	530	350	900	104	200	10
AD-S 2060	60	2050	1700	265	530	410	900	104	200	10
AD-S 25100	100	2550	2200	265	530	410	900	104	180	10
AD-S 30100	100	3050	2600	265	530	410	900	104	180	10
AD-S 30135	135	3050	2600	265	530	410	900	104	160	10
AD-S 30175	175	3050	2600	265	530	410	900	104	160	10
AD-S 30220	220	3050	2600	265	530	410	900	104	140	10
AD-S 30320	320	3050	2600	265	530	410	900	154	160	10
AD-S 37175	175	3700	3100	265	530	410	900	104	140	10
AD-S 37220	220	3700	3100	265	530	410	900	104	160	10
AD-S 40175	175	4050	3600	265	530	410	900	104	160	10
AD-S 40220	220	4050	3600	265	530	410	900	104	160	10
AD-S 40320	320	4050	3600	365	630	410	900	154	160	10
AD-S 40400	400	4050	3400	365	630	510	1040	300	140	8
AD-S 40600	600	4050	3100	365	700	510	990	300	80	7
AD-S 60220	220	6050	5100	265	530	410	1100	154	140	10
AD-S 60320	320	6050	5100	365	630	410	1100	154	140	10
AD-S 60400	400	6050	5100	365	630	510	1220	300	120	8
AD-S 60600	600	6050	5100	365	700	510	990	300	80	7
AD-S 60800	800	6050	5100	400	700	610	800	400	70	6
AD-S 70800	800	7050	5100	400	700	610	800	400	80	7
AD-S 701000	1000	7050	5100	500	800	610	800	400	70	5
AD-S 701250	1250	7050	5100	600	800	610	900	400	70	7
AD-S 80800	800	8050	6400	400	700	610	800	400	80	7
AD-S 801000	1000	8050	6400	500	800	610	800	400	70	5
AD-S 801250	1250	8050	6400	500	800	610	900	500	70	7
AD-S 801600	1600	8100	6400	400	1000	610	900	500	70	6

AD-S 802000	2000	8100	6400	600	1000	750	950	700	70	6
-------------	------	------	------	-----	------	-----	-----	-----	----	---

Machines set according to optimum values.

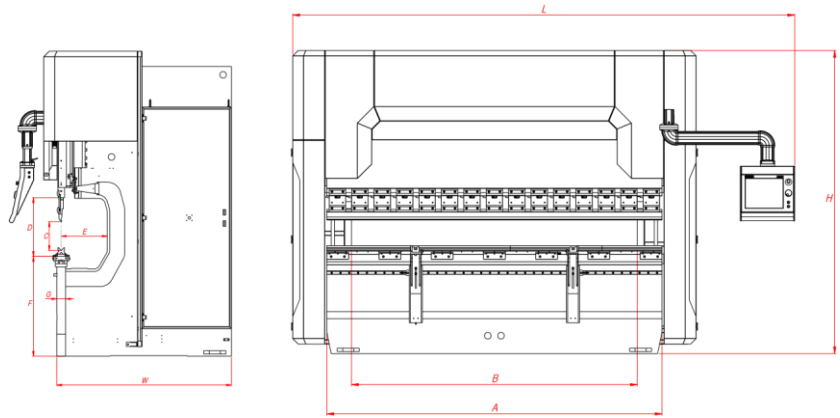

Y Return Speed	X Axes Working Speed	R Axes Working Speed	R Axes Working Distance	X Axes Distance			Motor Power	Length	Width	Height	Weight Approx.
				650	750	1000					
mm/sec	mm/sec	mm	mm				kW	mm	mm	mm	kg
								L	W	H	
110	500	350	250	-	S	-	7,5	2300	1200	2350	3100
110	500	350	250	S	-	O	7,5	3200	1200	2350	3550
120	500	350	250	S	-	O	11	3800	1670	2750	8900
120	500	350	250	S	-	O	11	4200	1670	2750	9500
120	500	350	250	S	-	O	15	4200	1680	2750	10500
100	500	350	250	S	-	O	18,5	4250	1700	2750	11500
140	500	350	250	S	-	O	22	4250	1770	2900	12500
140	500	350	250	S	-	O	37	4300	1820	3230	17500
100	500	350	250	S	-	O	18,5	4950	1700	2900	13000
120	500	350	250	S	-	O	22	4950	1770	2900	14360
140	500	350	250	S	-	O	18,5	5250	1700	2750	13100
140	500	350	250	S	-	O	22	5250	1770	2900	15000
140	500	350	250	-	S	O	37	5300	1910	3230	21000
120	350	300	250	-	S	O	37	5750	2110	3540	27000
80	350	300	250	-	S	O	45	5650	3250	3835	40500
120	350	300	250	-	S	O	22	7500	1770	3250	20840
120	350	300	250	-	S	O	37	7500	1910	3450	28500
100	350	300	250	-	S	O	37	7500	2110	3710	36000
80	350	300	250	-	S	O	45	7600	2650	3850	54000
80	350	300	250	-	S	O	55	8050	3200	4250	72000
70	350	300	250	-	S	O	55	8700	3200	4250	79500



60	300	250	250	-	-	S	55	8800	3250	5900	95500
70	300	250	250	-	-	S	90	8800	3250	6400	110000
70	300	300	250	-	S	O	55	9800	3200	4250	85000
60	300	250	250	-	-	S	55	10000	3250	5900	102000
70	300	250	250	-	-	S	90	10000	3250	6400	135000
70	300	250	250	-	-	S	90	10100	3500	7000	163000
60	300	250	250	-	-	S	110	10500	4350	8100	249000

S : Standard

O : Option

**DURMA**



FIBER LASER



PUNCH



PLASMA



L ANGLE PROCESSING CENTER

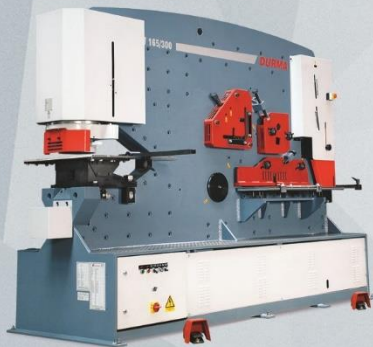

IRON WORKER



POWER OPERATED SHEAR

**DURMA**



PRESS BRAKE



VARIABLE RAKE SHEAR



ROLL BENDING



PROFILE BENDING



BANDSAW



CORNER NOTCHER



Today Tomorrow and Forever With You...

V	b	r <sub>i</sub>	s(mm)																					
			0.5	0.8	1	1.2	1.5	1.8	2	2.5	3	3.5	4	4.5	5	6	7	8	9	10	12	15	18	20
6	5	1	2,5	6,5	10																			
8	6	1,3	2	5	8	11																		
10	7	1,7	1,5	4	6	9	13																	
12	9	2		3	5	7	11	16																
15	12	2,7			4	6	9	13	16															
20	15	3,3				4	7	10	12	19														
26	18	4,2					4	7,5	9	14	21													
30	22	5						6,5	8	12	19	24												
32	23	5,4							7,5	11,6	17	23	30											
37	25	5,8								10	14,5	20	26	33										
42	29	6,7									13	17	23	29	33,5									
45	32	7,5										16	21	27	33	48								
50	36	8,3											19	24	30	43	58							
60	43	10												20	25	36	49	64						
70	50	11,5													21	31	42	55	69					
80	57	13,5														27	37	48	60	75				
90	64	15															32	42	54	66	95			
100	71	17																38	48	60	86	134		
130	93	22																	37	46	66	103	149	
180	130	30																		33	48	75	107	153
200	145	33																			43	67	83	119
250	180	42																				54	77	92

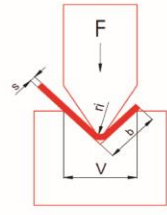

$$F = \frac{1,42 \times L \times Rm \times s^2}{1000 \times V} \text{ (Ton)}$$

F: Bending Force (Ton) L: Length(mm) r<sub>i</sub>: Inside Radius (mm) Rm: Material Tensile Strength (daN/mm<sup>2</sup>) V: Channel Width (mm) b: Minimum Sheet Bending Side (mm) s: Thickness (mm)

## AD-S SERIES PRESS BRAKES

Durmazlar Makina San. ve Tic. A.Ş.  
 OSB 75. Yıl Bulvarı Nilüfer-Bursa / Türkiye  
 P: +90 224 219 18 00  
 F: +90 224 242 75 80  
 info@durmazlar.com.tr  
 www.durmazlar.com.tr

